

# CSR INITIATIVE No.4 @ PUNE (2017-18)

<b>OBJECTIVE</b>	<i>Women empowerment through Tata Motors Girihini Welfare Society (established in 1973) by great visionary and mentor late Mrs Leelatai Moolgaokar. Welfare Society is ISO 9001 certified for quality.</i>
<b>ACTIVITY</b>	<i>Surface mounting technology line for pcb assembly for supply to Tata Motors</i>
<b>DATE OF COMMENCEMENT &amp; DURTION</b>	<i>July 2017 3 months</i>
<b>ANY PARNTNER OR NGO</b>	<i>Partnering with Tata Motors Girihini Welfare Society</i>
<b>LOCATION OF PROJECT</b>	<i>Telco colony, Pimpri, Pune 411018</i>
<b>BENIFICIARIES</b>	<i>25 to 30 ladies, who are spouses of employees of Tata Motors, as a part of woman empowerment and social commitment to support their family for improved standard of living.</i>
<b>MACHINE TO BE USED FOR ...</b>	<i>Automated PCB assembly used in vehicles</i>
<b>MONITORING &amp; MEASUREMENT MECHANISM</b>	<i>Monitoring production and turnover periodically.</i>
<b>Social Impact Assessment</b>	<p><i>An unique initiative of Tata Motors to provide empowerment to women, who are spouses of employees of Tata Motors with objective of providing sustained and better of standard of living. It is an ownership model with a difference where:</i></p> <ul style="list-style-type: none"> <li><i>• Woman Members (Shareholders) are employees of Tata Motors</i></li> <li><i>• A welfare Society is for the women and totally managed by the women</i></li> <li><i>• Members work only for five hours in a day</i></li> <li><i>• Work centers located in residential areas of this city and its industrial area. Woman are entitled to share of profits through dividend.</i></li> <li><i>• Monthly remuneration with statutory benefits is given to members.</i></li> <li><i>• Products produced by them are bought by Tata Motors to ensure sustenance and perpetual succession.</i></li> </ul>

**EVIDENTIAL GLIMPSES IN PICTURES**  
**(Machinery Layout)**

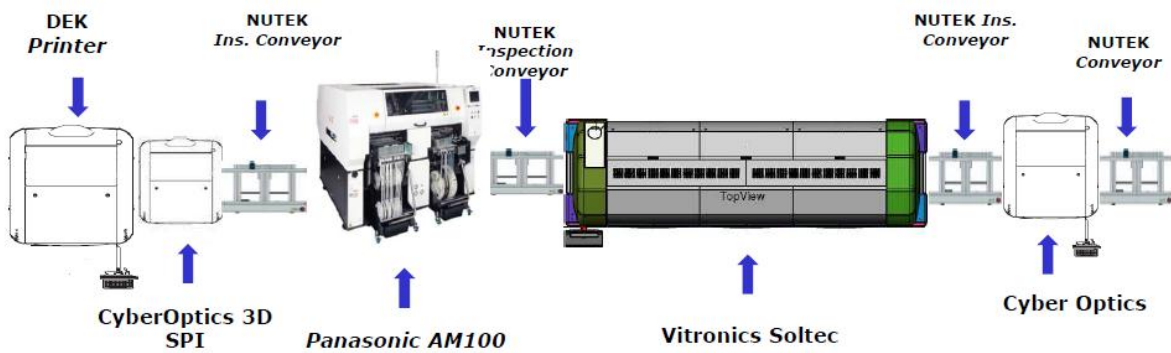
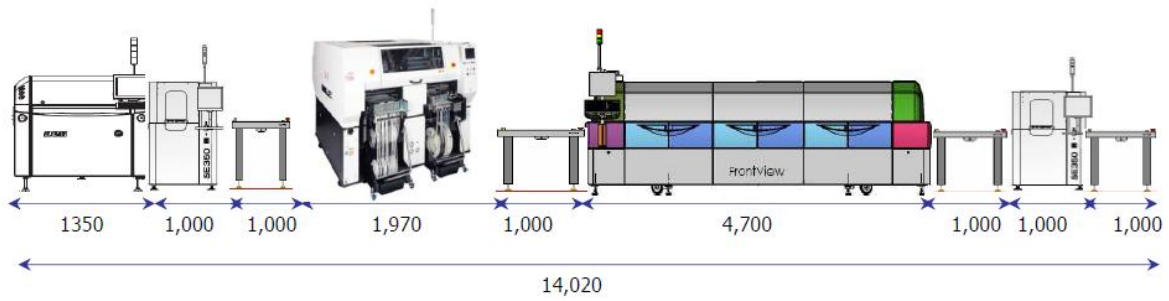

***Woman employees (spouses of TM employees) doing PCB job assembly for Tata Motors***



*Group snap of woman employees (left) and interactive training (right)*

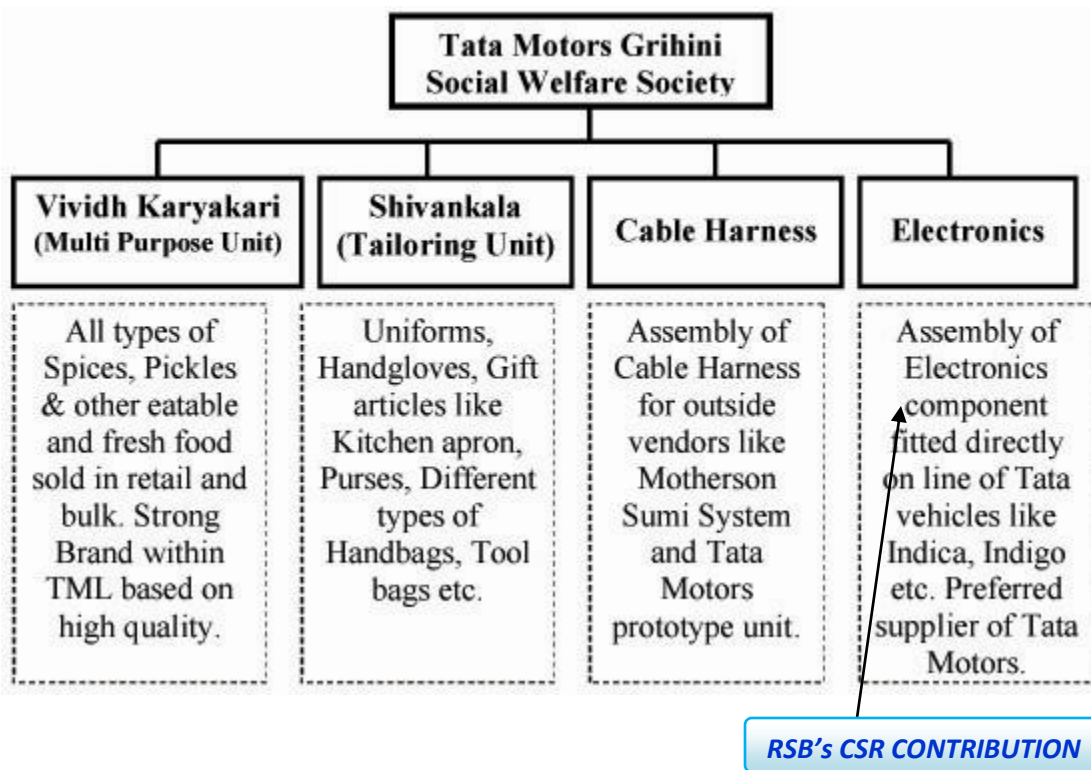

## **CONFORMANCE TO APPLICABLE LEGAL REQUIREMENTS**

**CSR Initiative conforms to Schedule VII, item (iii) of Ministry of Corporate Affairs Notification dated 27<sup>th</sup> Feb 2014.....**

- (iii) promoting gender equality, empowering women, setting up homes and hostels for women and orphans; setting up old age homes, day care centres and such other facilities for senior citizens and measures for reducing inequalities faced by socially and economically backward groups;